



新永威(淡邊)工業有限公司
TAMPIN SIN YONG WAI INDUSTRY SDN. BHD.
(323431-A)





0.083" SERIES

Gauge : V 2.1mm (0.083")

Diameter Head of Nails: 5.20mm
 Thickness Head of Nails: 0.70mm
 Copper Wire Diameter: 0.60mm

Threading Type:

FC : Smooth Shank
 FS : Screw Shank
 FR : Ring Shank

Nail Point:

Diamond Point (DP)
 Blunt Diamond Point (BDP)
 Blunt Chisel Point (BCP)

Cater and Fit to the following tools:

- * Bostitch N55C
- * MAX CN55
- * PASLODE 3225
- * Senco SCN55S, PalletPro57FXP
- * ATRO ROLL 60

Application

- Wooden packaging, construction of pallets, cases and wooden crates
- Window and door frames
- Panel sheathing and fencing

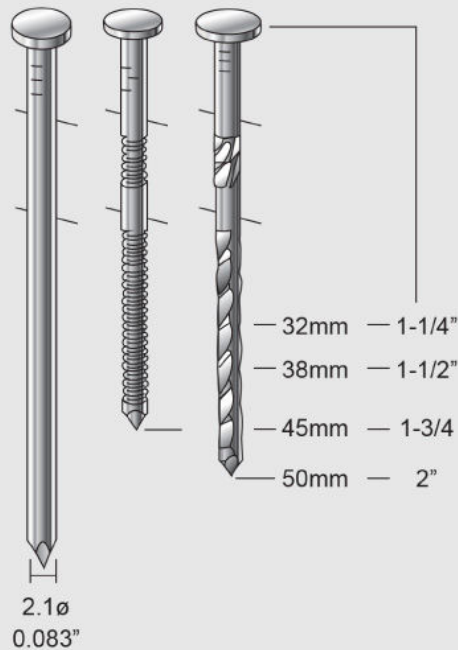

Product Information and Specification

Model	Length	Packaging Quantity	* M/CTN
32mm V2.1mm (0.083")	1-1/4"	350 pcs / 40 rolls / ctn	14M
38mm V2.1mm (0.083")	1-1/2"	350 pcs / 40 rolls / ctn	14M
45mm V2.1mm (0.083")	1-3/4"	350 pcs / 40 rolls / ctn	14M
50mm V2.1mm (0.083")	2"	350 pcs / 40 rolls / ctn	14M

* Approximately

0.092" SERIES



Gauge : V 2.3mm (0.092")

Diameter Head of Nails: 5.70mm
Thickness Head of Nails: 0.80mm
Copper Wire Diameter: 0.70mm

Threading Type:

FC : Smooth Shank

FS : Screw Shank

FR : Ring Shank

Nail Point:

Diamond Point (DP)

Blunt Diamond Point (BDP)

Blunt Chisel Point (BCP)

Cater and Fit to the following tools:

- * Bostitch N64C, N66C, N75C
- * MAX CN55 & CN565
- * Hitachi NV65AH
- * Senco SCN555

Application

- Wooden packaging, construction of pallets, cases and wooden crates
- Window and door frames
- Panel sheathing and fencing

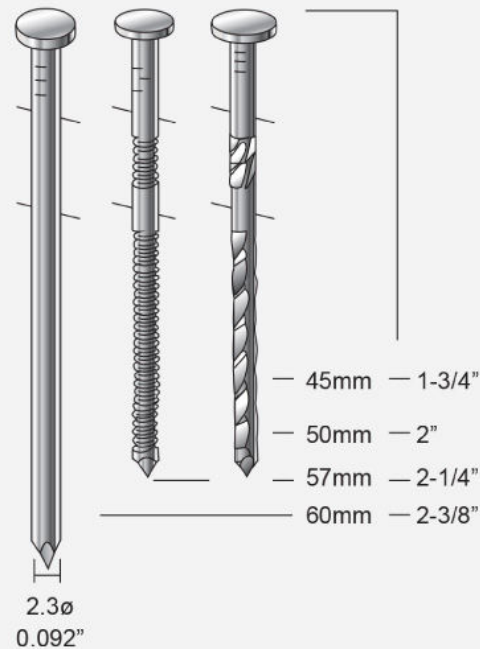

Product Information and Specification

Model	Length	Packaging Quantity	* M/CTN
45mm V2.3mm (0.092")	1-3/4"	300 pcs / 30 rolls / ctn	9M
50mm V2.3mm (0.092")	2"	300 pcs / 30 rolls / ctn	9M
57mm V2.3mm (0.092")	2-1/4"	300 pcs / 30 rolls / ctn	9M
60mm V2.3mm (0.092")	2-3/8"	300 pcs / 30 rolls / ctn	9M

* Approximately

0.113" SERIES



Gauge : V 2.9mm (0.113")

Diameter Head of Nails: 6.70mm

Thickness Head of Nails: 1.00mm

Copper Wire Diameter: 0.70mm

Threading Type:

FC : Smooth Shank

FS : Screw Shank

FR : Ring Shank

Nail Point:

Diamond Point (DP)

Blunt Diamond Point (BDP)

Blunt Chisel Point (BCP)

Cater and Fit to the following tools:

* Bostitch N75, N80CB-1

* MAX CN70 & CN80

* Hitachi NV65AC, 100XP

* ATRO RH C900/Roll 85

Application

- Wooden packaging, construction of pallets, cases and wooden crates
- Window and door frames
- Panel sheathing and fencing

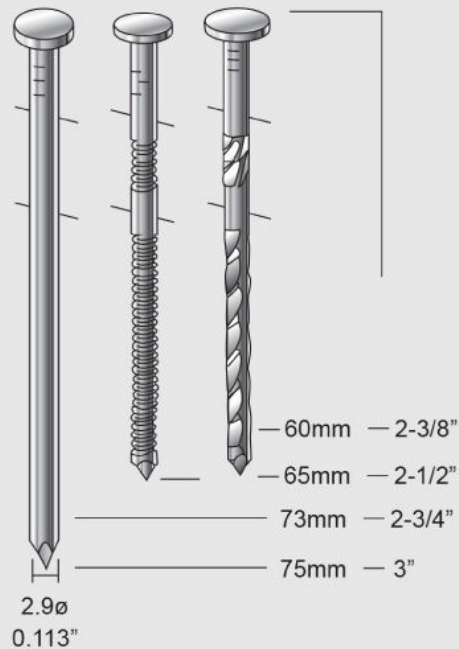

Product Information and Specification

Model	Length	Packaging Quantity	* M/CTN
60mm V2.9mm (0.113")	1-3/8"	250 pcs / 30 rolls / ctn	7.5M
65mm V2.9mm (0.113")	2-1/2"	250 pcs / 30 rolls / ctn	7.5M
73mm V2.9mm (0.113")	2-3/4"	255 pcs / 30 rolls / ctn	4.5M
75mm V2.9mm (0.113")	3"	255 pcs / 30 rolls / ctn	4.5M

* Approximately

0.099" SERIES



Gauge : V 2.5mm (0.099")

Diameter Head of Nails: 6.10mm
Thickness Head of Nails: 0.90mm
Copper Wire Diameter: 0.70mm

Threading Type:

FC : Smooth Shank
FS : Screw Shank
FR : Ring Shank

Nail Point:

Diamond Point (DP)
Blunt Diamond Point (BDP)
Blunt Chisel Point (BCP)

Cater and Fit to the following tools:

- * Bostitch N70, N80CB-1
- * MAX CN70 & CN80
- * ATRO ROLL 85
- * Hitachi NV65AC, NV83A
- * Makita AN902

Application

- Wooden packaging, construction of pallets, cases and wooden crates
- Window and door frames
- Panel sheathing and fencing

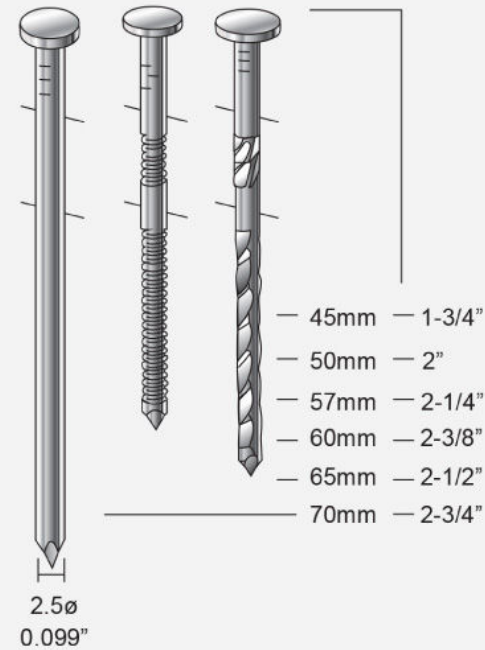

Product Information and Specification

Model	Length	Packaging Quantity	* M/CTN
45mm V2.5mm (0.099")	1-3/4"	300 pcs / 30 rolls / ctn	9M
50mm V2.5mm (0.099")	2"	300 pcs / 30 rolls / ctn	9M
57mm V2.5mm (0.099")	2-1/4"	300 pcs / 30 rolls / ctn	9M
60mm V2.5mm (0.099")	2-3/8"	300 pcs / 30 rolls / ctn	9M
65mm V2.5mm (0.099")	2-1/2"	300 pcs / 30 rolls / ctn	9M
70mm V2.5mm (0.099")	2-3/4"	300 pcs / 30 rolls / ctn	9M

* Approximately

0.120" SERIES



Gauge : W 3.1mm (0.120")

Diameter Head of Nails: 6.9mm
Thickness Head of Nails: 1.0mm
Copper Wire Diameter: 0.70mm

Threading Type:

FC : Smooth Shank
FS : Screw Shank
FR : Ring Shank

Nail Point:

Diamond Point (DP)
Blunt Diamond Point (BDP)
Blunt Chisel Point (BCP)

Cater and Fit to the following tools:

- * Bostitch N86C, N100C
- * Hitachi NV83A
- * Max CN80, CN890S
- * Makita AN902
- * Senco PalletPro 100XP, SCN65

Application

- Wooden packaging, construction of pallets, cases and wooden crates
- Window and door frames
- Panel sheathing and fencing

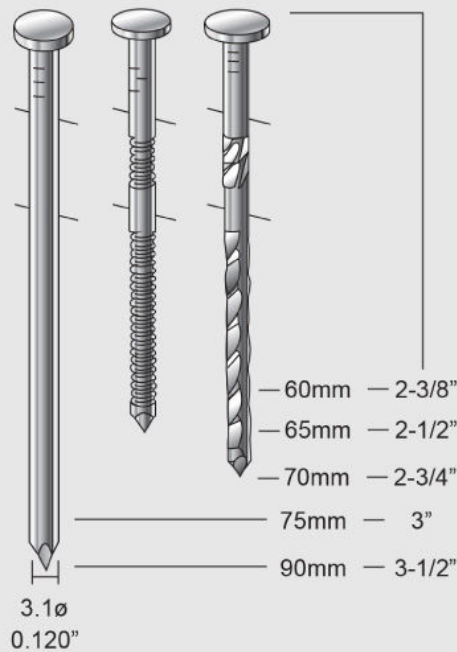

Product Information and Specification

Model	Length	Packaging Quantity	* M/CTN
60mm W3.1mm (0.120")	2-3/8"	225 pcs / 20 rolls / ctn	4.5M
65mm W3.1mm (0.120")	2-1/2"	225 pcs / 20 rolls / ctn	4.5M
70mm W3.1mm (0.120")	2-3/4"	225 pcs / 20 rolls / ctn	4.5M
75mm W3.1mm (0.120")	3"	225 pcs / 20 rolls / ctn	4.5M
90mm W3.1mm (0.120")	3-1/2"	225 pcs / 20 rolls / ctn	4.5M

* Approximately



15" Wire Collected High Load Coil 0.092 / 0.099 Series

Threading Type:
FC : Smooth Shank
FS : Screw Shank
FR : Ring Shank

Nail Point:
Diamond Point (DP)
Blunt Diamond Point (BDP)
Blunt Chisel Point (BCP)

Application

- Pallets manufacturing

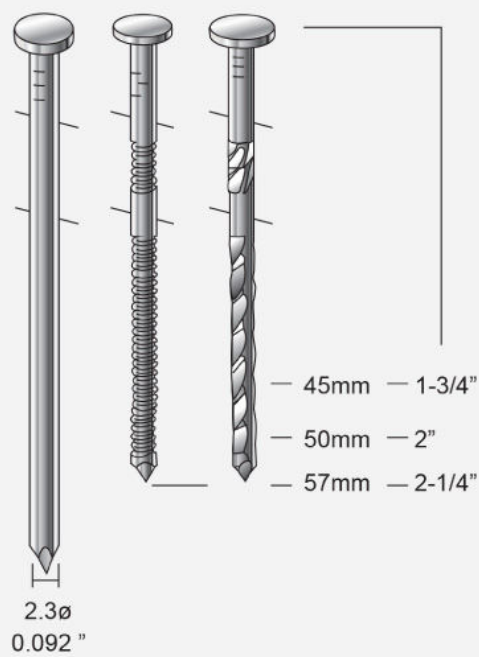

Product Information and Specification

Model	Length	Packaging Quantity	* M/CTN
50mm V2.3mm (0.092")	2"	3000 pcs / 3 rolls / ctn	9M
45mm V2.5mm (0.099")	1-3/4"	3000 pcs / 3 rolls / ctn	9M
50mm V2.5mm (0.099")	2"	3000 pcs / 3 rolls / ctn	9M
57mm V2.5mm (0.099")	2-1/4"	3000 pcs / 3 rolls / ctn	9M

* Approximately



Corporate Office & Tampin Factory
Lot 367 Kawasan Industri Taman Gunung Mas,
73000 Tampin, Negeri Sembilan, Malaysia.
Tel: +606-441 7450 Fax: +606-441 2335
Email: info@t-sinyongwai.com
shawn@t-sinyongwai.com

Nails Factory
Lot 68B, Jalan Usaha 12,
Kawasan Perindustrian Ayer Keroh,
75450 Melaka, Malaysia.
Tel : +606-2321311 Fax : +606-2320313

Website: www.t-sinyongwai.com

